

Estonian Energy Service Company
www.energiateenus.ee

Lokaalse mikro- ja väikekoostootmise võimalused ettevõtetele



Criss Uudam
AU Energiateenus OÜ
criss@energiateenus.ee

Millega tegeleme?

Energia- ja ressursiaudit

Energiatõhususprojektid

Tehnosüsteemide hooldus ja kaugseire

Hooneautomaatika lahendused

Lokaalse energiatootmise lahendused



Milline koostootmisjaam sobib asukohta?

Puiduhake, puidutööstuse jäätmed, pelletid

Maagaas → Mootor, turbiin, kütuseelement ?

Koostootmisjaama projekt

CHP tasuvusarvutused ja otsustusprotsess

Projekteerimine ja ehitusloa taotlemine

Elektrivõrguga liitumine ja toetused

Ehitus ja opereerimine

CHP tasuvusarvutused ja otsustusprotsess

Soojusenergia tarbimine
Elektrienergia tarbimine → Trendid

Soojuse hind
Elektri hind → Trendid

Elektrivõrguga tootja liitumine

Katlamaja ümberehituse vajadus

Aktsiisid, TE tasu, TE toetus, otseliin

Sobiva tehnoloogia ja tootja valik

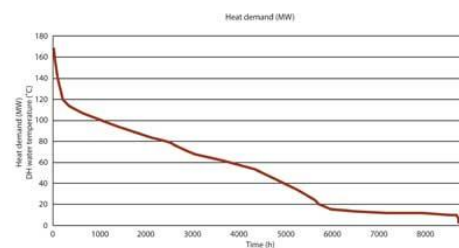

CHP tasuvusarvutused ja otsustusprotsess

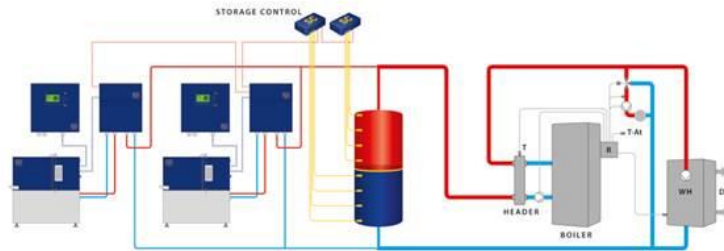
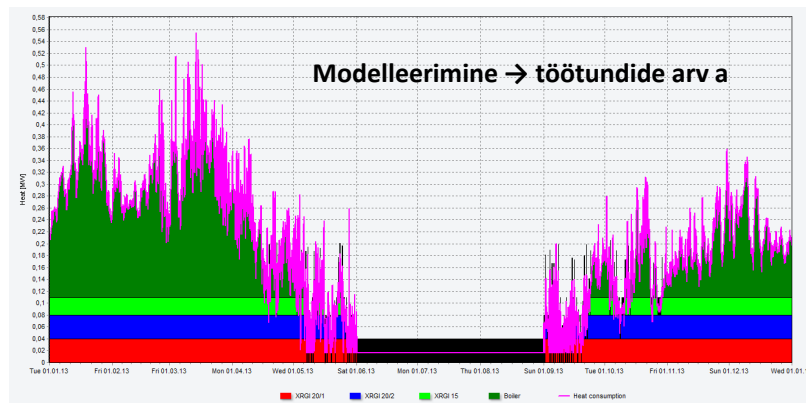

Sobiv tehnoloogia



Sobiv tehnoloogia

Continuous modulation of 10 – 20 kW in power-controlled mode

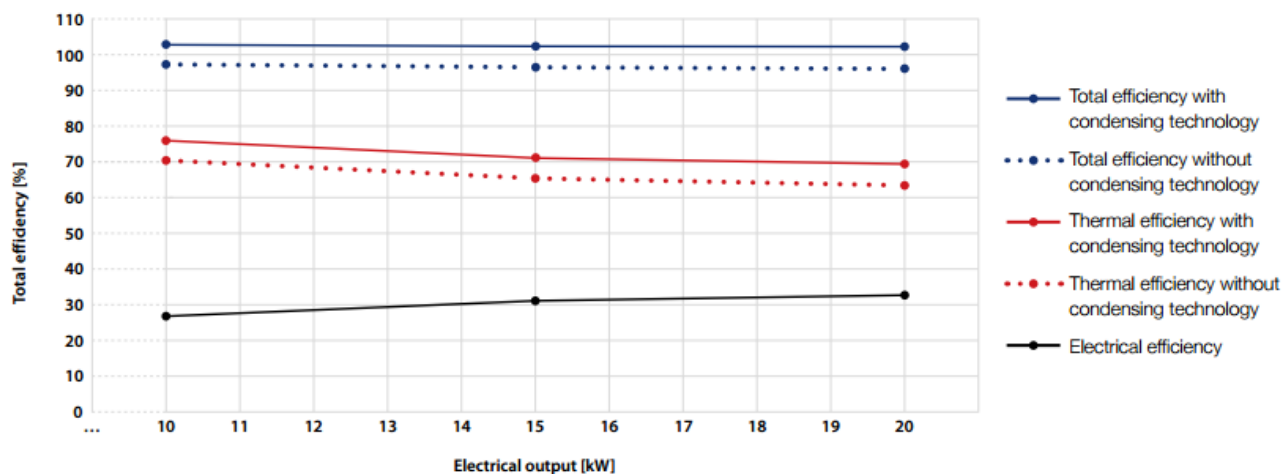

Projekteerimine ja lubade protseduurid

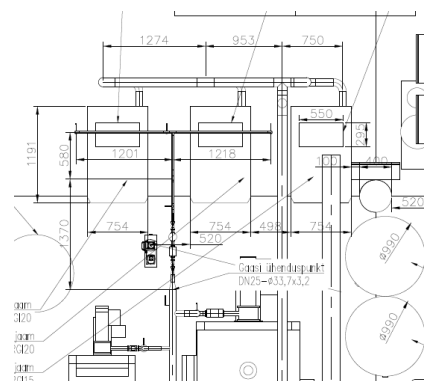
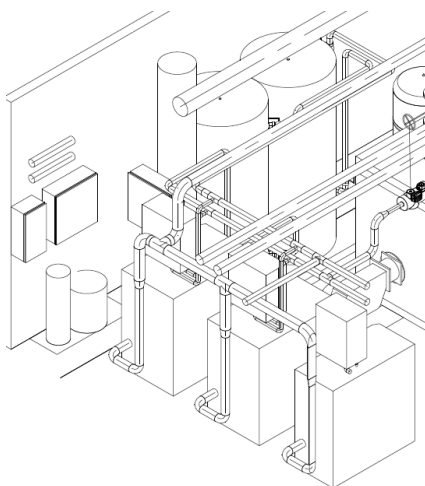

Kooskõlastamised: KDV, Keskkonnaamet, jaotusvõrk, Elering, EMTA, KA ...

Elektrivõrguga liitumine ja toetused

Omatarbe katmine + elektri ülejäägi võrku müümine

Otseliin ja toetus kogu tarbitud elektrilt

Ehitus ja opereerimine

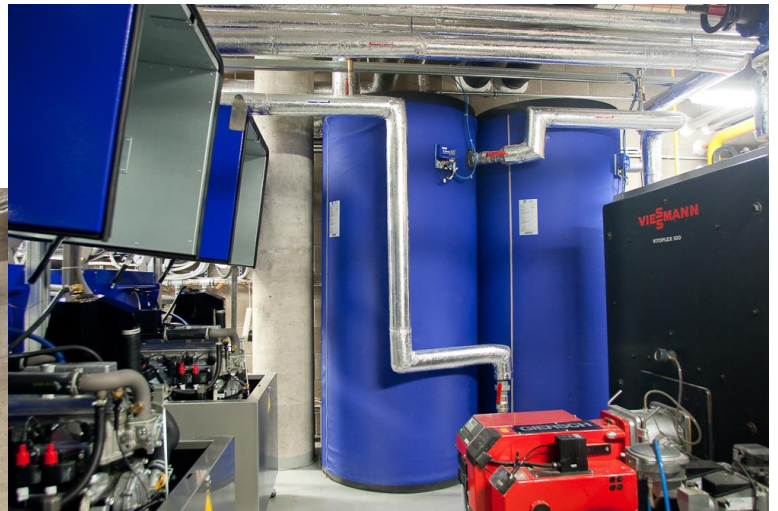

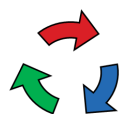

Estonian Energy Service Company
www.energiateenus.ee

TÄNAN TÄHELEPANU EEST!



Criss Udam
+372 51 999 493
AU Energiateenus OÜ
criss@energiateenus.ee